

# 15. APTA SS-M-015-06

## Standard for Wheel Flange Angle for Passenger Equipment

Approved May 18, 2007  
**APTA PRESS Task Force**

Authorized June 2, 2007  
**APTA Commuter Rail Executive Committee**

**Abstract:** This standard defines the minimum flange angle and the minimum length of surface on the flange, over which the angle must be maintained. These wheel flange parameters are important in reducing the risk of low speed wheel climb derailments. The standard also provides drawings of wheel profiles that are compliant with the requirements of this standard.

**Key Words:** railroad wheel, flange angle, low speed wheel climb derailment, wheel profile, rail profile, Nadal.

Copyright © 2007 by  
The American Public Transportation Association  
1666 K Street, N. W.  
Washington, DC 20006-1215  
All rights reserved.

*No part of this publication may be reproduced in any form,  
in an electronic retrieval system or otherwise,  
without the prior written permission of  
The American Public Transportation Association.*

## Introduction

(This introduction is not part of APTA SS-M-015-06, Standard for Wheel Flange Angle for Passenger Equipment.)

In November 1998, APTA issued Technical Bulletin 1998-1, on Commuter Car Safety Regarding: Wheel Running Surface Manufacture and Reprofiling Contour. The bulletin recommended a minimum flange angle of  $72^{\circ}$  (suggested tolerance  $+3^{\circ}$  and  $-2^{\circ}$ ) be achieved at the gage point,  $3/8$  inch above the standard base line.

The 1998-1 Technical Bulletin is superseded by this standard which requires that on all new and reprofiled wheels, a flange angle of no less than  $72^{\circ}$  shall exist over a continuous length of at least 0.1 inches along the surface of the flange where it will contact the rail.

The standard also provides drawings of narrow flange wheel profiles that are compliant with the requirements of this standard. Some wheel profiles currently in use such as the AAR S-621-79 can produce flange angles less than that required in this standard due to variation in tolerances. Railroads choosing to continue the use of the AAR S-621-79 wheel profile, should observe strict adherence to the railroad's quality assurance plan to confirm that tolerance stack-ups do not cause non-compliance with the flange angle requirements of this standard.

## Participants

The American Public Transportation Association (APTA) greatly appreciates the contributions of the following individual(s), who provided the primary effort in the drafting of the *Standard for Wheel Flange Angle for Passenger Equipment*:

Steve Dedmon, <i>Chair</i>	Cameron Lonsdale	David Schanoes	Brian Whitten
Susan Kristoff	Brian Marquis	Mark Stewart	

At the time this standard was completed, the Passenger Rail Equipment Safety Standards (PRESS) Mechanical Committee included the following members:

### **Dave Carter, *Chair***

Steven Abramopoulos	Chuck Florian	Keith McCarrick	Carlos Sosa
M. Andriani	Greg Gagarin	Don Minini	Rex Springston
Gordon Bachinsky	John Goliber	Heiner Moehren	Mark Stewart
Jack Barnas	Jeff Gordon	Donald Morrissey	Monique Stewart
Ken Barnish	Thomas Grant	Dak Murthy	Philip M. Strong
Al Bieber	Harry Haber	Larry Niemond	Chris Studcart
George Binns	Kevin Heidrich	Thomas O'Brien	Dick Swaney
Brad Black	Francois Henri	Frank Orioles	Bob Swearingen
Rick Brilz	Ken Hesser	George Payne	Ali Tajaddini
Chris Brockhoff	Christopher Holliday	Fernando Pascual	KI. Takeshita
Dick Bruss	Paul E. Jamieson	Tom Peacock	Joe Talafous
Dave Brooks	James Jewell	John Pearson, Jr.	Clive Thornes
Mark Campbell	Richard Johnson	Jim Pilch	Richard Trail
Gary Carr	Joe Kalousek	Ian Pirie	Mike Trosino
John Casale	Joe Kahr	Richard Polley	Tom Tsai
Al Cheren	Bob Kells	John Posterino	Bob Tuzik
George A. Chipko	Larry Kelterborn	Anand Prabhakaran	Richard Vadnal
Steve Chrismer	Kevin Kesler	Chuck Prehm	Arun Virginkar
Roger Collen	Paul Kezmarsky	John Punwani	John Wagner
Richard Conway	Peter Klauser	Russ Quimby	David Warner
Steve Costanzo	Sunil Kondapalli	James G. Rees	Douglas Warner
Jack Coughlin	John P. Konrad	Al Roman	Charles Whalen
Tim Cumbie	Susan Kristoff	Carol Rose	Brian Whitten
Erik Curtis	Rick Laue	Tom Rowbottom	Gary Widell
Graham Curtis	Nicolas Lessard	Daniel Ruppert	James Wilson
Richard Curtis	Jason Lipscomb	John Rutkowski	Bruce Wigod
Steve Dedmon	Cameron Lonsdale	Tom Rusin	Werner H. Wodtke
John M. Dermody	Ben Lue	Michele Salvatore	Clifford Woodbury
Greg Dvorchak	William Lydon	Radovan Sarunac	Bob Wright
Ed Deitt	Susan Madigan	Fred Schaerr	P. Yablonsky
Magdy El-Sibaie	Dan Magnus	Hans-Dieter Schaller	H. Yamamori
John Elkins	Eric Magel	David Schanoes	Greg Yovich
Dave Elliott	Frank Maldari	Peter Schumacher	Allan Zaremski
Owen Evans	George Manessis	Bill Sears	John Zolock
Gary Fairbanks	Jean Major	Rebecca Sidelinger	Steve Zuiderveen
Ronald L. Farrell	John Mardente	Kevin Simms	
Andrew F. Farilla	James Martin	Tom Simpson	
Benoit Filion	Brian Marquis	Albert C. Song	

## Table of Contents

1. Overview .....	15.5
1.1 Scope .....	15.5
1.2 Purpose .....	15.5
2. References .....	15.5
3. Definitions, abbreviations, and acronyms .....	15.6
3.1 Definitions .....	15.6
3.2 Abbreviations and acronyms .....	15.6
4. Flange Angle Criteria .....	15.7
5. Inspection and Maintenance .....	15.7
5.1 Inspection .....	15.7
5.2 Maintenance .....	15.7
Annex A (informative) Wheel Flange Angle .....	15.8
Annex B (normative) Wheel Profiles .....	15.10
B.1 Purpose .....	15.10
B.2 APTA 120 Wheel Profile .....	15.11
B.3 APTA 140 Wheel Profile .....	15.12
B.4 APTA 140M Wheel Profile .....	15.13
B.5 APTA 220 Wheel Profile .....	15.14
B.6 APTA 240 Wheel Profile .....	15.15
B.7 APTA 320 Wheel Profile .....	15.16
B.8 APTA 340 Wheel Profile .....	15.17
Annex C (informative) Bibliography .....	15.18

# APTA SS-M-015-06

## Standard for Wheel Flange Angle for Passenger Equipment

### 1. Overview

#### 1.1 Scope

This wheel flange angle standard applies to all new and reprofiled wheels used on railroad passenger equipment of all types, including non-passenger carrying cars and locomotives that are intended for use in passenger service on the general railway system of the United States. Other wheel parameters including tread taper are outside the scope of this standard.

The passenger rail industry will phase this standard into practice over the 36 month period from June 30, 2007 to July 1, 2010.

#### 1.2 Purpose

The purpose of this document is to provide minimum requirements for the wheel flange angle to reduce the risk of wheel climb derailments. See Annex A.

This standard supersedes APTA Technical Bulletin 1998-1, on Commuter Car Safety Regarding: Wheel Running Surface Manufacture and Reprofile Contour. The bulletin recommended a minimum flange angle of 72° (suggested tolerance +3° and -2°) be achieved at the gage point, 3/8 inch above the standard base line.

### 2. References

This standard, where applicable, shall be used in conjunction with the following publications. If the following publications are superseded by an approved revision, the approved revision shall apply.

AAR Manual of Standards and Recommended Practices, Section G-II, Figure 4.37 (Concluded), Narrow Flange Tapered Tread Contour – Locomotive and Amtrak (former Standard S-621-79)

AAR Manual of Standards and Recommended Practices, Section G, Figure B.12, AAR-1B Narrow Flange Contour for Freight Car Wheels (Standard S-669)

### 3. Definitions, abbreviations, and acronyms

#### 3.1 Definitions

**3.1.1 flange angle:** The flange angle ( $\delta$ ) is the maximum angle found on the surface of the wheel flange, measured with respect to the axis of the wheel set as shown in Figure 1.

**Figure 1 - Flange Angle Definition**

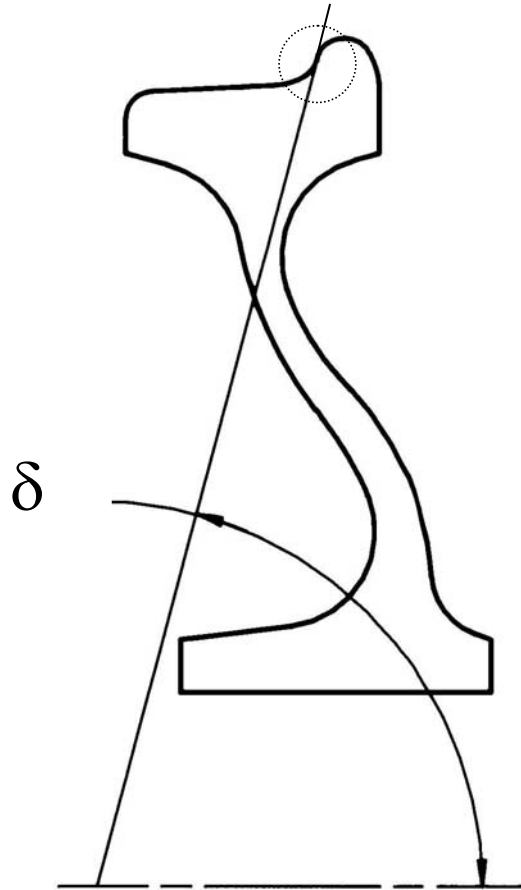

#### 3.2 Abbreviations and acronyms

AAR	Association of American Railroads
APTA	American Public Transportation Association
CSTT	Centre for Surface Transportation Technology (division of National Research Council Canada)
FRA	Federal Railroad Administration
NRCC	National Research Council Canada
PRESS	Passenger Rail Equipment Safety Standards

## 4. Flange Angle Criteria

On all new and reprofiled wheels, a flange angle of no less than  $72^\circ$  shall exist over a continuous length of at least 0.1 inches along the surface of the flange, as shown in Figure 2, where it would contact the rail should the wheel climb. Annex B provides examples of wheel profiles which meet this requirement with new rail profiles<sup>1</sup>.

The minimum flange angle of  $72^\circ$  includes manufacturing tolerances. In deciding on a flange angle to meet the minimum specified, inspectability and manufacturing tolerances shall be considered.

**Figure 2 - Flange Angle Standard Criteria**

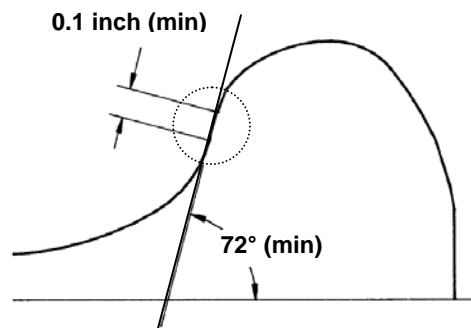

## 5. Inspection and Maintenance

### 5.1 Inspection

New and reprofiled wheels shall be inspected in accordance with the railroad's quality assurance plan to confirm the acceptability of the flange angle. Acceptable inspection methods include, but are not limited to, go/no-go gauges, templates, or automated measuring tools. The quality assurance plan shall require verification of the accuracy and ability of the inspection tool to discriminate between compliant and non-compliant flange angles and to establish a test frequency that provides adequate control of wheel profiling.

### 5.2 Maintenance

This standard is not intended to establish guidelines for the inspection or rejection of wheel flange angles while in service. Typically, flange wear results in a steeper flange angle, so the need for verification applies more to new and reprofiled flange and tread contours. However, if a railroad has experience with flange angles that decrease with wear, APTA recommends that periodic maintenance inspections of the flange angle be established. Flange angles that decrease with wear can occur when introducing a new higher flange angle wheel on rail that has worn to the original, lower flange angle wheel.

<sup>1</sup> New rail profiles used – 100, 112, 115, 119, 132, 136 and 140 RE.

## Annex A (informative) Wheel Flange Angle

In discussing wheel/rail interaction, an understanding of the wheel/rail interface is important. The wheel flange angle is an important part of a system that includes many variables, each of which contributes in its own way to the overall behavior of the wheel as it moves along the rail. The potential for a low speed flange climb derailment can be decreased when all of these variables, including flange angle are addressed in a comprehensive rail management program. Nadal [C9] described some of these variables in the early 1900’s that include friction control in addition to the flange angle. Rail gage spreading, superelevation, rail camber, angle of attack, duration/distance traveled of excess L/V ratio and the variables that affect these parameters also play an important role in wheel climb derailments.

The main factors in wheel/rail interaction and their relationship are stated clearly in Nadal’s formula:

$$Nadal \left( \frac{L}{V} \right) = \frac{\tan(\delta) - \mu}{1 + \mu \tan(\delta)} \quad (1)$$

where:  $\mu$  = coefficient of friction between wheel and rail.

The variables in (1) are illustrated in Figure A1. The variable delta is that angle which is formed when the wheel flange surface and rail gage face surface are in contact. A worn wheel and/or rail profile can greatly affect the wheel/rail interface contact angle. Managing the contact angle as outlined in this standard is an integral part of any wheel/rail interface management strategy. The flange angle is used as an approximation of the maximum contact angle.

**Figure A1 - Wheel/Rail Interaction Variables.**

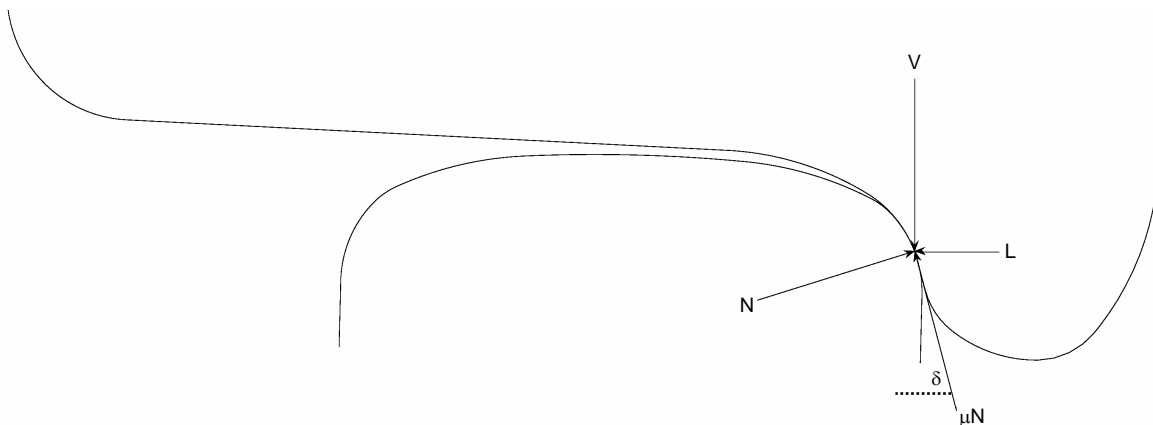

Nadal's formula provides an insight into the potential for wheel climb between a specific wheel and a specific rail under specific conditions. Nadal's formula is an industry accepted approach and is utilized because it is simple and straightforward, appropriate for maintaining safety and the variables can be measured.

Based on this formula, railroads have sought to optimize the wheel/rail interface by controlling the coefficient of friction through lubrication schemes, the rail gage face angle through grinding processes, and the wheel flange angle through periodic reprofiling. Some commuter railroads have adopted the AAR-1B profile (developed for freight wheels) as a wheel flange standard, because the profiled flange wears into a relatively optimal contour for maintaining a steep flange angle.

The flange angle specification outlined in this standard requires that the maximum angle be maintained over a distance, rather than at a discrete point. This will increase the probability that a high interface or contact angle between the wheel and rail is maintained despite variations in wheel and rail profiles.

## Annex B (normative) Wheel Profiles

### B.1 Purpose

This annex provides drawings of APTA Standard wheel profiles. The narrow flange wheel profiles listed in the table below are examples that meet the requirements<sup>2</sup> of this standard.

<b>APTA Wheel Profiles</b>			
<b>Annex</b>	<b>Series</b>	<b>Designation</b>	<b>Description</b>
B.2	100	120	Based on (former) AAR S-621-79, 1:20 taper
B.3		140	Based on (former) AAR S-621-79 with 1:40 taper
B.4		140M	Based on (former) AAR S-621-79 with 1:40 taper modified by NJT to provide flange angle of 72°-75°
B.5	200	220	Based on AAR-1B (AAR S-669), 1:20 taper, modified for 5.5 inch wheel width
B.6		240	Based on AAR-1B (AAR S-669) modified for 1:40 taper and 5.5 inch wheel width
B.7	300	320	NRCC-COM20 developed by CSTT [C8] and funded by FRA
B.8		340	NRCC-COM40 developed by CSTT [C8] and funded by FRA

<sup>2</sup> Compliance with requirements based on analysis of wheel-to-rail contact geometry using 1:40 tie plate, 56.5 inch track gage and 53-3/16 inch wheel back-to-back dimension.

B.2

APTA 120 Wheel Profile

Based on (former) AAR S-621-79, 1:20 taper.

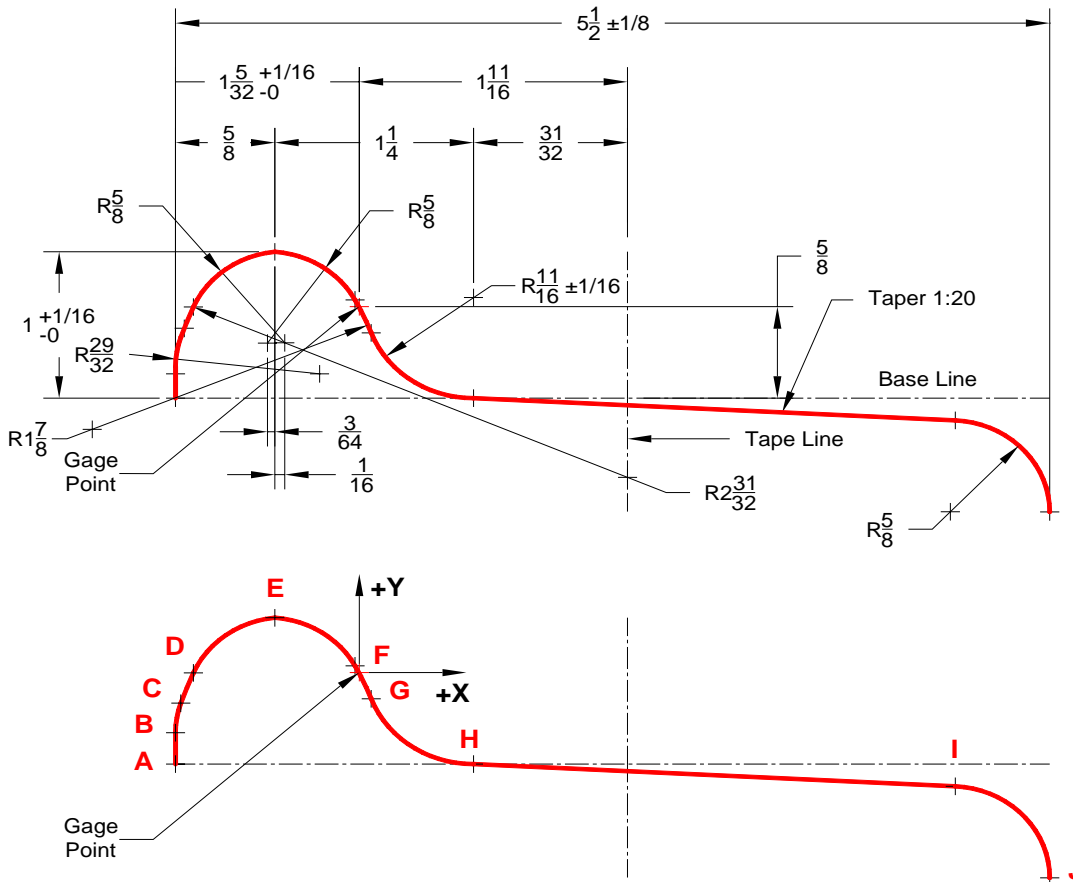

Node Coordinates			Segment Details			
Point	X	Y	Segment	Radius Line	X - Center	Y - Center
A	-1.1563	-0.6250	A - B	Line 90°		
B	-1.1562	-0.4583	B - C	0.9063	-0.2500	-0.4583
C	-1.1013	-0.1476	C - D	2.9688	1.6875	-1.1654
D	-1.0438	-0.0019	D - E	0.6250	-0.4688	-0.2469
E	-0.5313	0.3750	E - F	0.6250	-0.5781	-0.2482
F	-0.0270	0.0465	F - G	1.8750	-1.6805	-0.8376
Gage Point	0.0000	0.0000				
G	0.0751	-0.1790	G - H	0.6875	0.7188	0.0625
H	0.7188	-0.6250	H - I	Line 1:20		
I	3.7500	-0.7766	I - J	0.6250	3.7188	-1.4008
J	4.3438	-1.4008	Beyond J	Line 90°		

Note: All coordinates relative to 'Gage Point', and all dimensions are inches. Flange angle must be no less than 72° over a continuous length of at least 0.1 inch.

B.3

APTA 140 Wheel Profile

Based on (former) AAR S-621-79 with 1:40 taper.

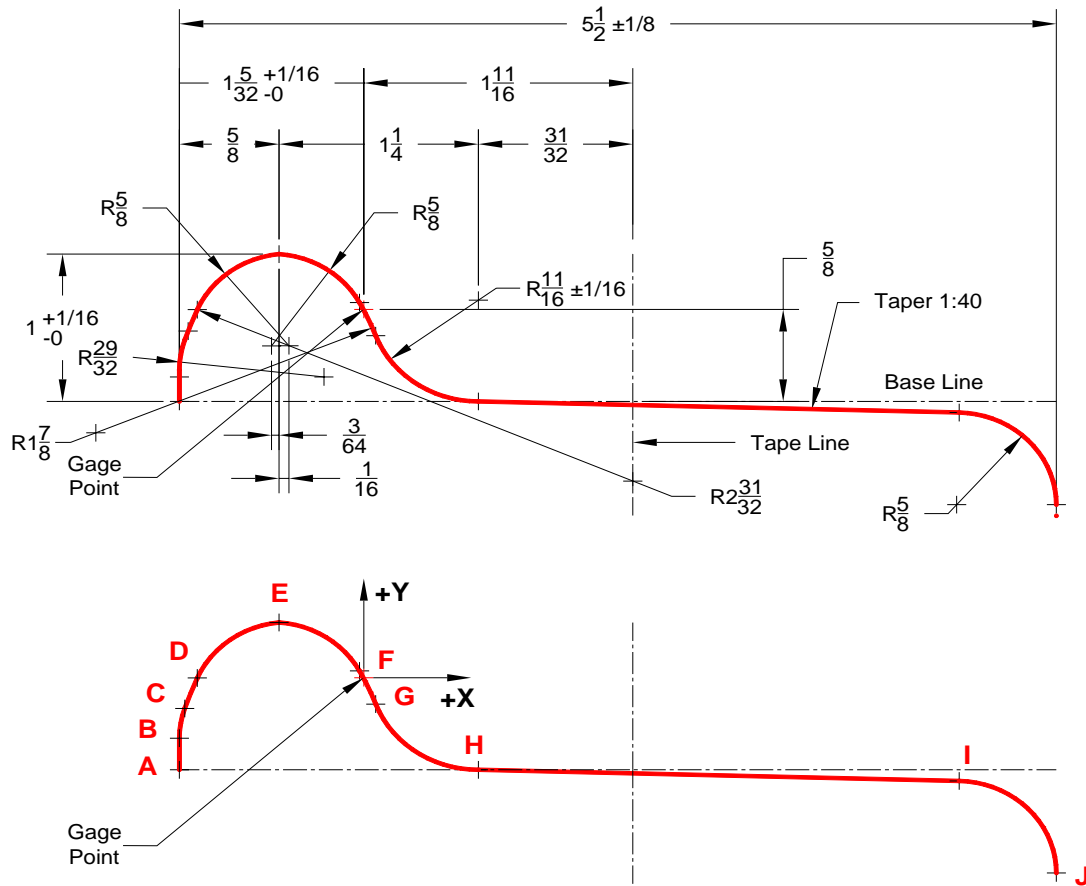

Node Coordinates			Segment Details			
Point	X	Y	Segment	Radius Line	X - Center	Y - Center
A	-1.1563	-0.6250	A - B	Line 90°		
B	-1.1562	-0.4583	B - C	0.9063	-0.2500	-0.4583
C	-1.1013	-0.1476	C - D	2.9688	1.6875	-1.1654
D	-1.0438	-0.0019	D - E	0.6250	-0.4688	-0.2469
E	-0.5313	0.3750	E - F	0.6250	-0.5781	-0.2482
F	-0.0270	0.0465	F - G	1.8750	-1.6805	-0.8376
Gage Point	0.0000	0.0000				
G	0.0751	-0.1790	G - H	0.6875	0.7188	0.0625
H	0.7188	-0.6250	H - I	Line 1:40		
I	3.7344	-0.7004	I - J	0.6250	3.7188	-1.3252
J	4.3438	-1.3252	Beyond J	Line 90°		

Note: All coordinates relative to 'Gage Point', and all dimensions are inches. Flange angle must be no less than 72° over a continuous length of at least 0.1 inch.

B.4

APTA 140M Wheel Profile

Based on (former) AAR S-621-79 with 1:40 taper modified by NJT to provide flange angle of 72°-75.

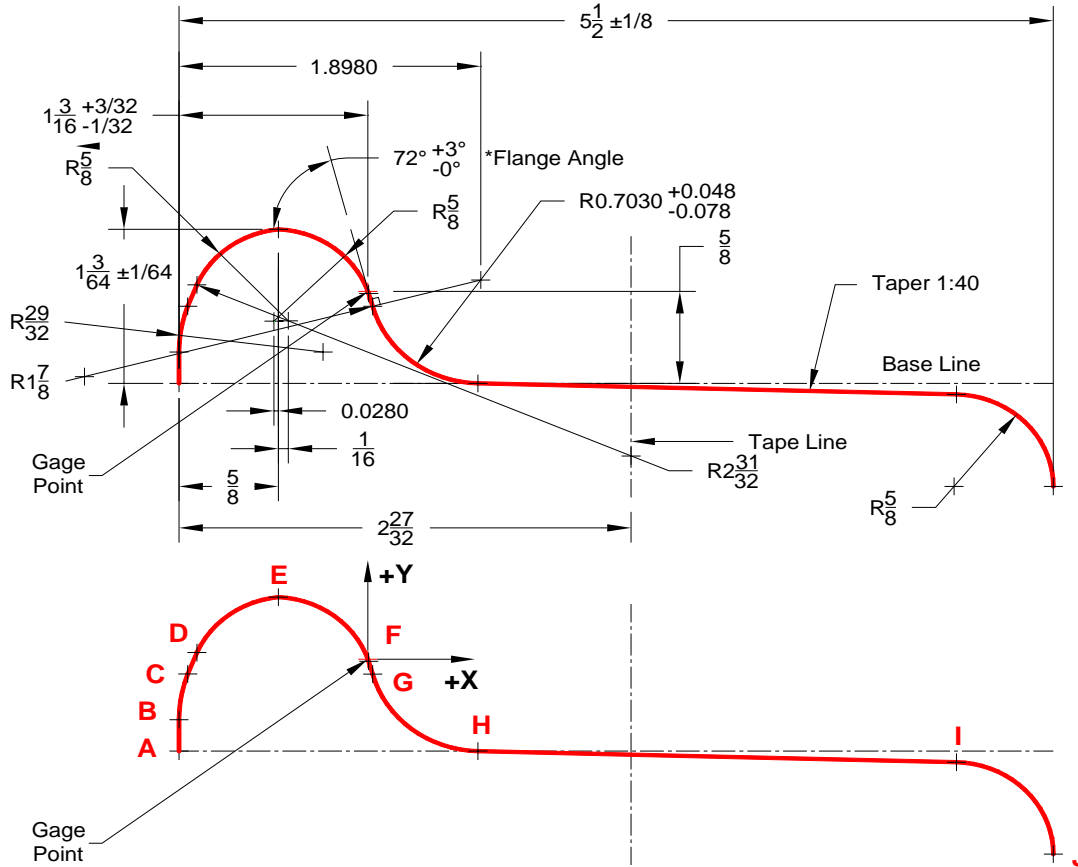

Node Coordinates			Segment Details			
Point	X	Y	Segment	Radius Line	X - Center	Y - Center
A	-1.1875	-0.6250	A - B	Line 90°		
B	-1.1875	-0.4114	B - C	0.9063	-0.2813	-0.4114
C	-1.1326	-0.1007	C - D	2.9688	1.6563	-1.1186
D	-1.0750	0.0450	D - E	0.625	-0.5000	0.2000
E	-0.5625	0.4219	E - F	0.625	-0.5905	-0.2025
F	0.0054	-0.0141	F - G	1.875	-1.7824	-0.5793
Gage Point	0.0000	0.0000				
G	0.0307	-0.1014	G - H	0.703	0.7105	0.0778
H	0.6929	-0.6250	H - I	Line 1:40		
I	3.7031	-0.7003	I - J	0.625	3.6875	-1.3251
J	4.3125	-1.3251	J - K	Line 90°		

Note: All coordinates relative to 'Gage Point', and all dimensions are inches.  
 \*Flange angle must be no less than 72° over a continuous length of at least 0.1 inch.

### B.5 APTA 220 Wheel Profile

Based on AAR-1B (AAR S-669), 1:20 taper, modified for 5.5 inch wheel width.

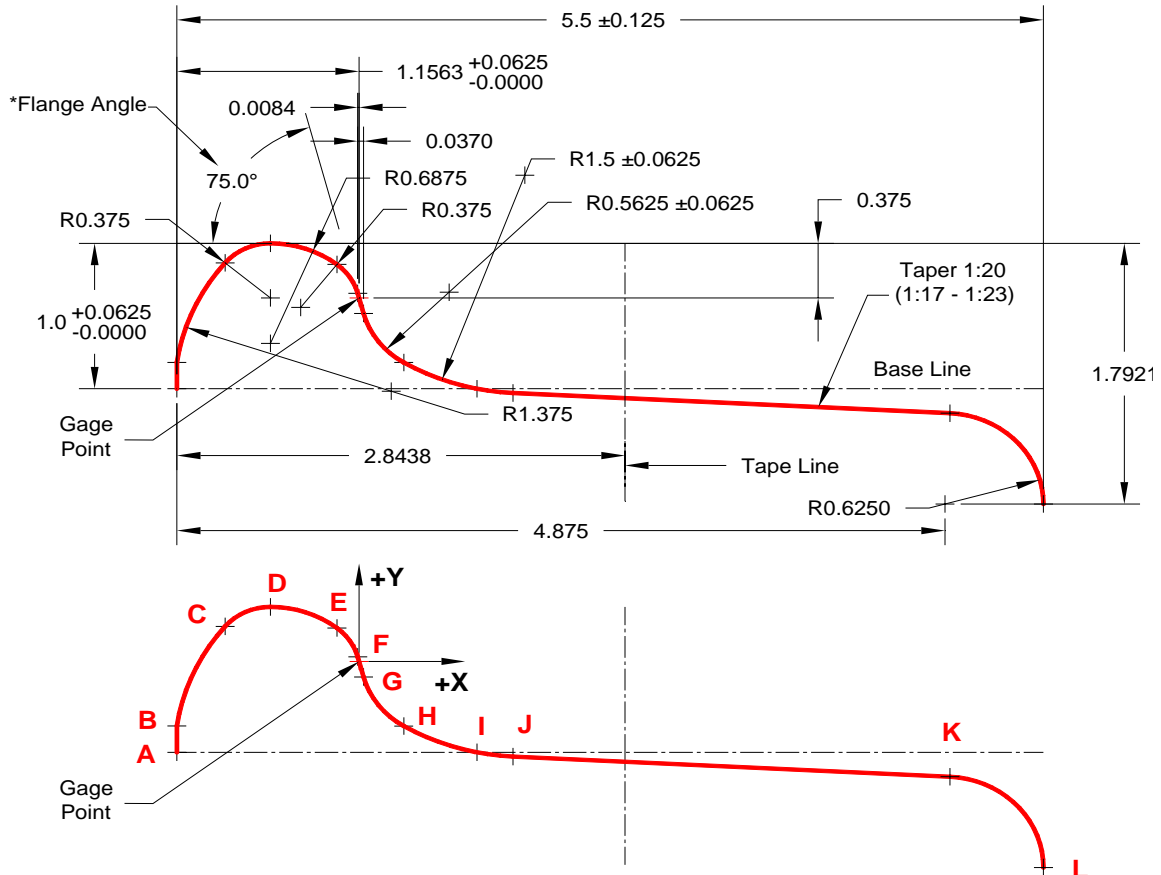

Node Coordinates			Segment Details			
Point	X	Y	Segment	Radius Line	X - Center	Y - Center
A	-1.1563	-0.6250	A - B	Line 90°		
B	-1.1563	-0.4434	B - C	1.375	0.2044	-0.6418
C	-0.8501	0.2407	C - D	0.375	-0.5625	0.0000
D	-0.5625	0.3750	D - E	0.6875	-0.5625	-0.3125
E	-0.1403	0.2301	E - F	0.375	-0.3706	-0.0659
F	-0.0084	0.0312	F - G	Line 75°		
Gage Point	0.0000	0.0000				
G	0.0286	-0.1069	G - H	0.5625	0.5720	0.0387
H	0.2840	-0.4445	H - I	1.5	1.0520	0.8440
I	0.7485	-0.6250	I - J	1.5	1.0520	0.8440
J	0.9771	-0.6542	J - K	Line 1:20		
K	3.7499	-0.7927	K - L	0.625	3.7187	-1.4169
L	4.3437	-1.4169	Beyond L	Line 90°		

Note: All coordinates relative to 'Gage Point', and all dimensions are inches.  
 \*Flange angle must be no less than 72° over a continuous length of at least 0.1 inch.

### B.6 APTA 240 Wheel Profile

Based on AAR-1B (AAR S-669) modified for 1:40 taper and 5.5 inch wheel width.

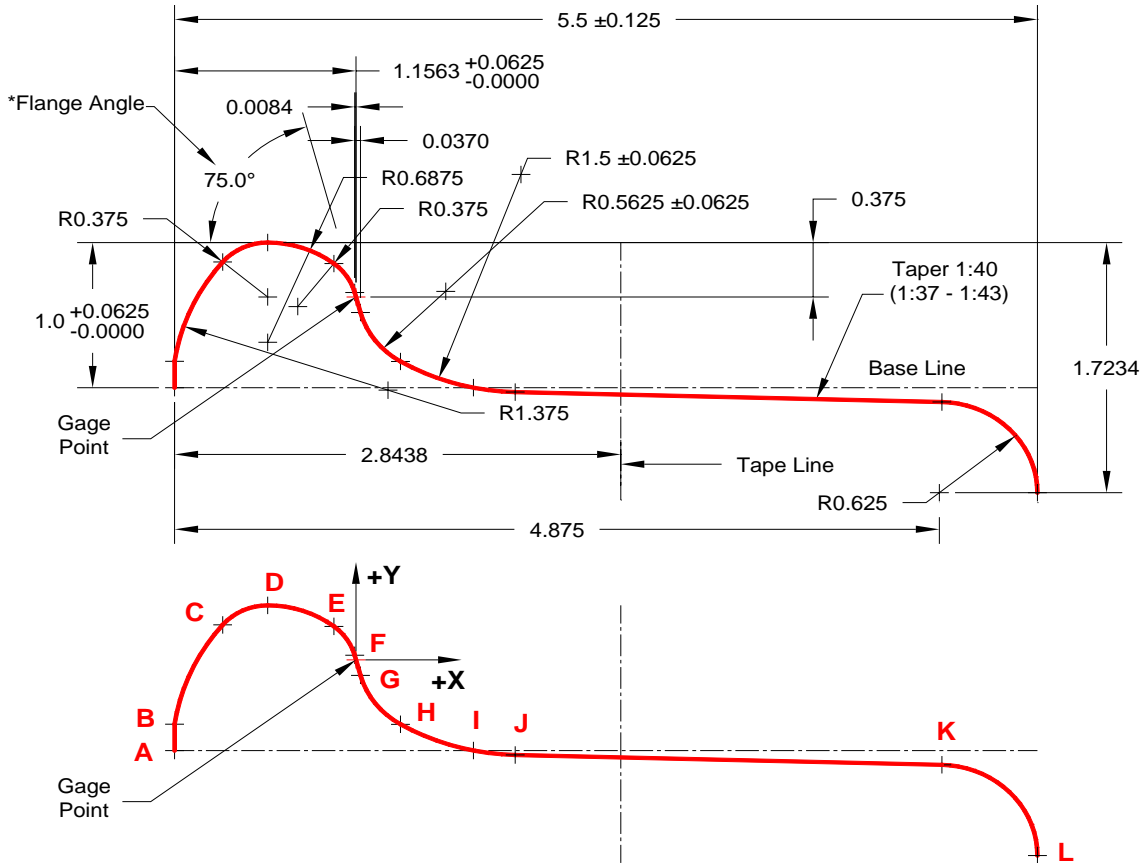

Node Coordinates			Segment Details			
Point	X	Y	Segment	Radius Line	X - Center	Y - Center
A	-1.1563	-0.6250	A - B	Line 90°		
B	-1.1563	-0.4434	B - C	1.375	0.2044	-0.6418
C	-0.8501	0.2407	C - D	0.375	-0.5625	0.0000
D	-0.5625	0.3750	D - E	0.6875	-0.5625	-0.3125
E	-0.1403	0.2301	E - F	0.375	-0.3706	-0.0659
F	-0.0084	0.0312	F - G	Line 75°		
Gage Point	0.0000	0.0000				
G	0.0286	-0.1069	G - H	0.5625	0.5720	0.0387
H	0.2840	-0.4445	H - I	1.5	1.0520	0.8440
I	0.7485	-0.6250	I - J	1.5	1.0520	0.8440
J	1.0148	-0.6556	J - K	Line 1:40		
K	3.7344	-0.7236	K - L	0.625	3.7187	-1.3484
L	4.3437	-1.3483	Beyond L	Line 90°		

Note: All coordinates relative to 'Gage Point', and all dimensions are inches.  
 \*Flange angle must be no less than 72° over a continuous length of at least 0.1 inch.

B.7

APTA 320 Wheel Profile

NRCC-COM20 developed by CSTT and funded by FRA.

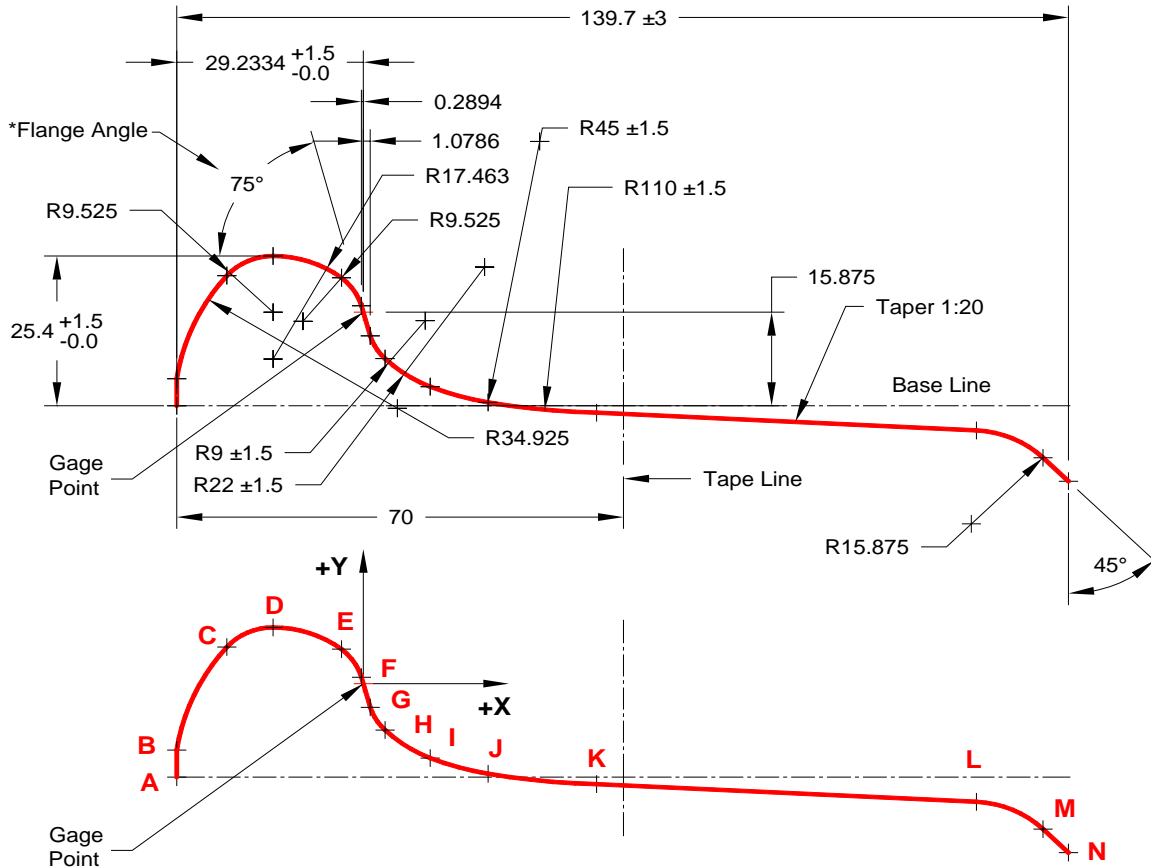

Point	X	Y	Segment	Radius Line	X - Center	Y - Center
A	-29.2334	-15.8750	A - B	Line 90°		
B	-29.2334	-11.2780	B - C	34.925		
C	-21.3784	6.2040	C - D	9.525		
D	-14.1504	9.5250	D - E	17.463		
E	-3.4274	5.8440	E - F	9.525		
F	-0.2894	1.0800	F - G	Line 75°		
Gage Point	0.0000	0.0000				
G	1.0786	-4.0250	G - H	9		
H	3.4066	-7.8752	H - I	22		
I	10.4796	-12.6340	I - J	45		
J	19.5616	-15.3010	J - K	110		
K	36.5386	-17.0500	K - L	Line 1:20		
L	96.0526	-20.0600	L - M	15.875		
M	106.4856	-24.6900	M - N	Line 45°		
N	110.4666	-28.6710	Beyond N	Line 90°		

Note: All coordinates relative to 'Gage Point' and all dimensions are millimeters.  
 \*Flange angle must be no less than 72° over a continuous length of at least 0.1 inch.

B.8

APTA 340 Wheel Profile

NRCC-COM40 developed by CSTT and funded by FRA.

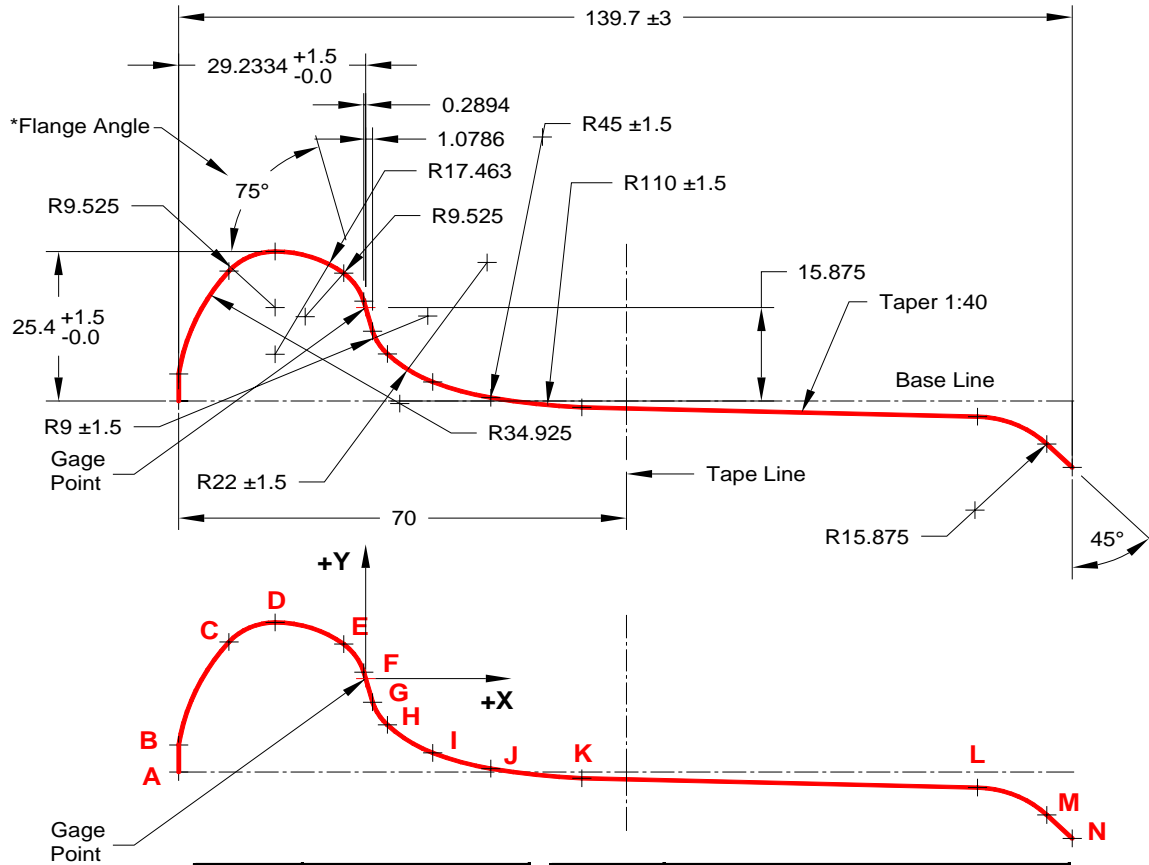

Point	X	Y	Segment	Radius Line	X - Center	Y - Center
A	-29.2334	-15.8750	A - B	Line 90°		
B	-29.2334	-11.2780	B - C	34.925		
C	-21.3784	6.2040	C - D	9.525		
D	-14.1504	9.5250	D - E	17.463		
E	-3.4274	5.8440	E - F	9.525		
F	-0.2894	1.0800	F - G	Line 75°		
Gage Point	0.0000	0.0000				
G	1.0786	-4.0250	G - H	9		
H	3.4066	-7.8752	H - I	22		
I	10.4796	-12.6340	I - J	45		
J	19.5616	-15.3010	J - K	110		
K	33.7946	-16.9470	K - L	Line 1:40		
L	95.6566	-18.5280	L - M	15.875		
M	106.4856	-23.1730	M - N	Line 45°		
N	110.4666	-27.1540	Beyond N	Line 90°		

Note: All coordinates relative to 'Gage Point' and all dimensions are millimeters.  
 \*Flange angle must be no less than 72° over a continuous length of at least 0.1 inch.

## Annex C (informative) Bibliography

- [C1] Ban, T., Kakishima, H., Iida, K., Maebashi, E., Ishida, H., Ishida, M., "A Study on the Coefficient of Friction between Rail Gauge Corner and Wheel Flange Focusing on Wheel Machining", *14th International Wheelset Congress*, Orlando, Florida, Oct. 17-21, 2004.
- [C2] Barbosa, R.S., "A 3D Contact Force Safety Criterion for Flange Climb Derailment of a Railway Wheel", *Vehicle System Dynamics*, 42(5) (2004), pp. 289-300.
- [C3] Elkins, J. and Wu, H. "Angle of Attack and Distance Based Criteria for Flange Climb Derailment", *Vehicle System Dynamics*, 33(Suppl.) (1999), pp. 293-305.
- [C4] Gilchrist, A.O. and Brickle, B.V. "A Re-Examination of the Proneness to Derailment of a Railway Wheel-Set", *Journal of Mechanical Engineering Science*, – *IMEchE* 18(3) (1976), pp. 131-141.
- [C5] Leary, J., Gudiness, T., "The Engineering and Economic Aspects of the AAR-1B Wheel Profile," Report No. R-808, Association of American Railroads, Transportation Test Center, Pueblo, CO, April 1992.
- [C6] Lewis, R., Ekberg, A., Bruni, S., Dwyer-Joyce, R.S., "A Design Tool for Railway Wheels Incorporating Damage Models and Dynamic Simulations", *IEEE/ASME Joint Railroad Conference*, Paper RTD2005-70038, Pueblo, Colorado, March 16-18, 2005.
- [C7] Magel, Eric, "Optimizing Wheel and Rail Profiles on Amtrak's Northeast Corridor", *Interface, The Journal of Wheel/Rail Interaction*, Sept. 2004.
- [C8] Magel, Eric, "Development of a Generic Wheel Profile and Matching Rail Profiles for Commuter Systems", CSTT Report #CSTT-HVC-LR-222, June 2005.
- [C9] Nadal, M.J., "Locomotives a Vapeur, Collection Encyclopedie Scientifique", *Bibliothèque de Mécanique Appliquée et Génie*, 186. Paris, France, 1908.
- [C10] R-Sany, J., "Another Look at the Single Wheel Derailment Criterion", *Proceedings - IEEE/ASME Joint Rail Conference*, Oak Brook, IL, 1996, pp. 17-22.
- [C11] Railway Industrial Standard TB/T 449 - 2003, "Profiles of Wheel Flange Tread for Locomotives and Cars", Ministry of Railway of the People's Republic of China, 2003.
- [C12] Shu, X., Wilson, N., Wu, H., Tunna, J., "A Bi-parameter Distance Criterion for Flange Climb Derailment", *Proceedings - IEEE/ASME Joint Railroad Conference*, Paper RTD2005-70007, Pueblo, Colorado, March 16-18, 2005.
- [C13] Shust, W., Elkins, J., "Wheel Forces During Flange Climb Part I - Track Loading Vehicle Tests", *Proceedings - IEEE/ASME Joint Rail Conference*, Boston, MA, 1997.
- [C14] Shust, W., Elkins, J., "Wheel Forces During Flange Climb Part II - NUCARS Simulations", *Proceedings - IEEE/ASME Joint Rail Conference*, Boston, MA, 1997.
- [C15] Weinstock, H., "Wheel Climb Derailment Criteria for Evaluation of Rail Vehicle Safety", *ASME Winter Annual Meeting*, Paper 84-WA/RT-1, 1984.
- [C16] Wu, H., "Wheel/Rail Profile Design and Maintenance", *10th Annual AAR Research Review*, TTCI, Pueblo, Colorado, March 15, 2005.